

ST1152B

Version : A.001
Issue Date : 2008/03/17
File Name : SP-ST1152B-A.001.doc
Total Pages : 8

*Low-saturation, Low-voltage
Bi-directional Motor Driver*



新竹市展業一路9號7樓之1

SILICON TOUCH TECHNOLOGY INC.

9-4F-3, Prosperity Rd I, Science-Based Industrial Park
Hsinchu, Taiwan, R.O.C.

Tel : 886-3-5727171 Fax : 886-3-5727390

ST1152B

Low-saturation, Low-voltage Bi-directional Motor Driver

General Specifications

The device is a two-channel low-saturation bi-directional motor driver IC. The design is optimal for stepper-motor applications, such as toy, cameras, printers or other portable devices.

Features and Benefits

- Low voltage operation ($V_{DD\ min} = V_{S1\ min} = V_{S2\ min} = 1.5V$)
- High current output (max. 1.5A/channel)
- Built-in thermal shutdown circuit
- Built-in pull down resistor
- Low saturation voltage (Upper transistor + low transistor residual voltage; 0.3V typ. at 400mA, 0.6V typ. at 750mA)
- Parallel connection (two-channel driver: Upper transistor + low transistor residual ; 0.4V typ. at 800mA)
- Separate control logic power supply and motor driver power supply
- Brake function
- High output sinking and driving capability
- Thin, highly reliable package (DIP-14,SOP14)

Pin Assignment

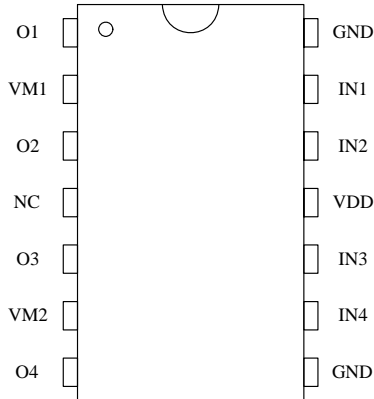

Pin NO.	Pin Name	Description
1	O1	Output sinking / driving pin
2	VM1	Power supply pin for driver
3	O2	Output sinking / driving pin
4	NC	No connection
5	O3	Output sinking / driving pin
6	VM2	Power supply pin for driver
7	O4	Output sinking / driving pin
8	GND	Ground pin
9	IN4	Input pin 4 that determines driving mode
10	IN3	Input pin 3 that determines driving mode
11	VDD	Power supply pin for controller.
12	IN2	Input pin 2 that determines driving mode
13	IN1	Input pin 1 that determines driving mode
14	GND	Ground pin

Absolute Maximum Ratings (Unless otherwise noted, $T_A=25^{\circ}\text{C}$)

Characteristic	Symbol	Rating	Unit
Supply Voltage	V_{DD}	7.0	V
	V_M	7.0	V
Input Voltage	V_{IN}	$V_{DD}+0.4$	V
I_{ODC} Maxium Current Per Channel (DIP14)	I_{ODC1}	1.5	A
I_{ODC} Maxium Current Per Channel (SOP14)	I_{ODC2}	1.3	A
Power Dissipation	P_D	800	mW
Operating Temperature Range	T_{OPR}	-40 ~ 150	$^{\circ}\text{C}$
Storage Temperature Range	T_{STG}	-65 ~ 150	$^{\circ}\text{C}$

Electrical Characteristic (Unless otherwise noted, $T_A = 25^\circ\text{C}$ & $V_{DD} = V_M = 3\text{V}$)

Characteristic	Sym.	Condition	Limit			Unit
			Min.	Typ.	Max.	
Supply Voltage	V_{DD}		1.5	3	7.0	V
	V_S		1.5	3	7.0	V
Supply Current ($I_{DD} + I_S$)	I_{DD0}	$V_{IN1, IN2, IN3, IN4} = 0\text{V}$		0.1	10	μA
	I_{DD1}	$V_{IN1}=3\text{V}, V_{IN2, IN3, IN4}=0\text{V}$		0.1	1	mA
IN1 / IN2 / IN3 / IN4 Input Terminal ($T_J = 25^\circ\text{C}$)						
Input Voltage "H"	V_{IH}	-	$0.5 \cdot V_{DD}$	-	$V_{DD} + 0.4$	V
Input Voltage "L"	V_{IL}	-	-0.4	-	$0.2 \cdot V_{DD}$	V
Input Current "H"	I_{IH}	$V_{IN} = V_{DD} = 3\text{V}$	30	50	70	μA
Input Current "L"	I_{IL}	$V_{IN} = 0\text{V}$	-	-	± 5	μA
O1 / O2 / O3 / O4 Output Terminal ($T_J = 25^\circ\text{C}$)						
Output Voltage (upper + lower)	V_{OUT1}	$I_{OUT} = 200\text{ mA}$	-	0.15	0.3	V
	V_{OUT2}	$I_{OUT} = 400\text{ mA}$	-	0.3	0.6	V
	V_{OUT3}	$I_{OUT} = 750\text{ mA}$	-	0.6	0.95	V
	V_{OUT4}	$I_{OUT} = 400\text{ mA}$ (parallel connection)	-	0.2	0.35	V
	V_{OUT5}	$I_{OUT} = 800\text{ mA}$ (parallel connection)	-	0.4	0.7	V
Thermal Protection Circuit						
Protection Temperature	T_{TSD}	$V_{EN} = V_{DD}$		150		$^\circ\text{C}$

Truth Table

IN1 / IN3	IN2 / IN4	O1 / O3	O2 / O4	Mode
H	L	H	L	Forward
L	H	L	H	Reverse
H	H	H	H	Brake
L	L	OFF	OFF	Standby

Block Diagram & Application Circuit

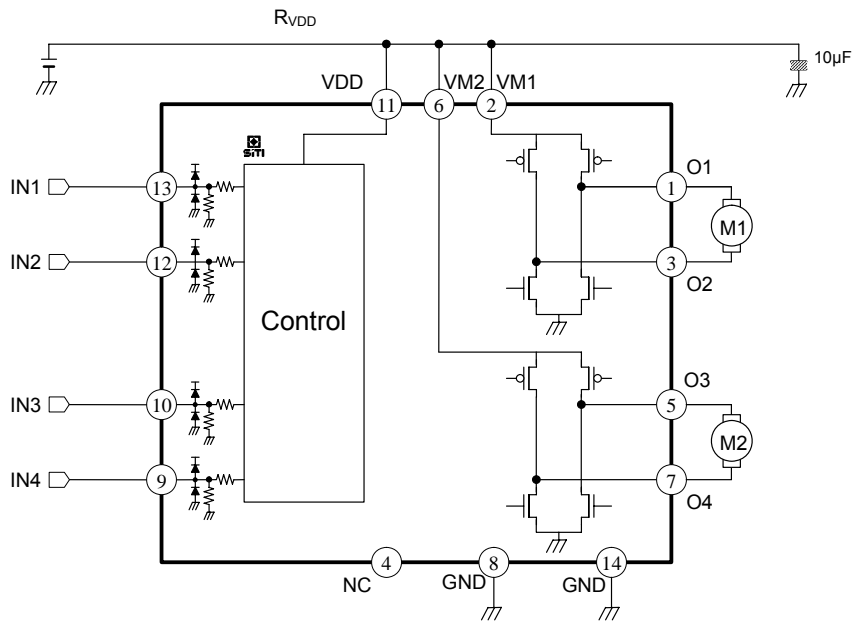

Application Notes

- The power dissipated by the IC varies widely with the supply voltage, the output current, and loading. It is important to ensure the application does not exceed the allowable power dissipation of the IC package. The recommended motor driver power dissipation versus temperature is depicted as follows:

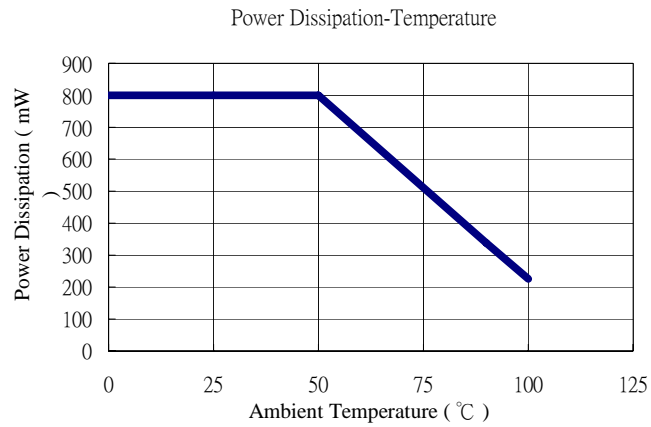

Package Specification

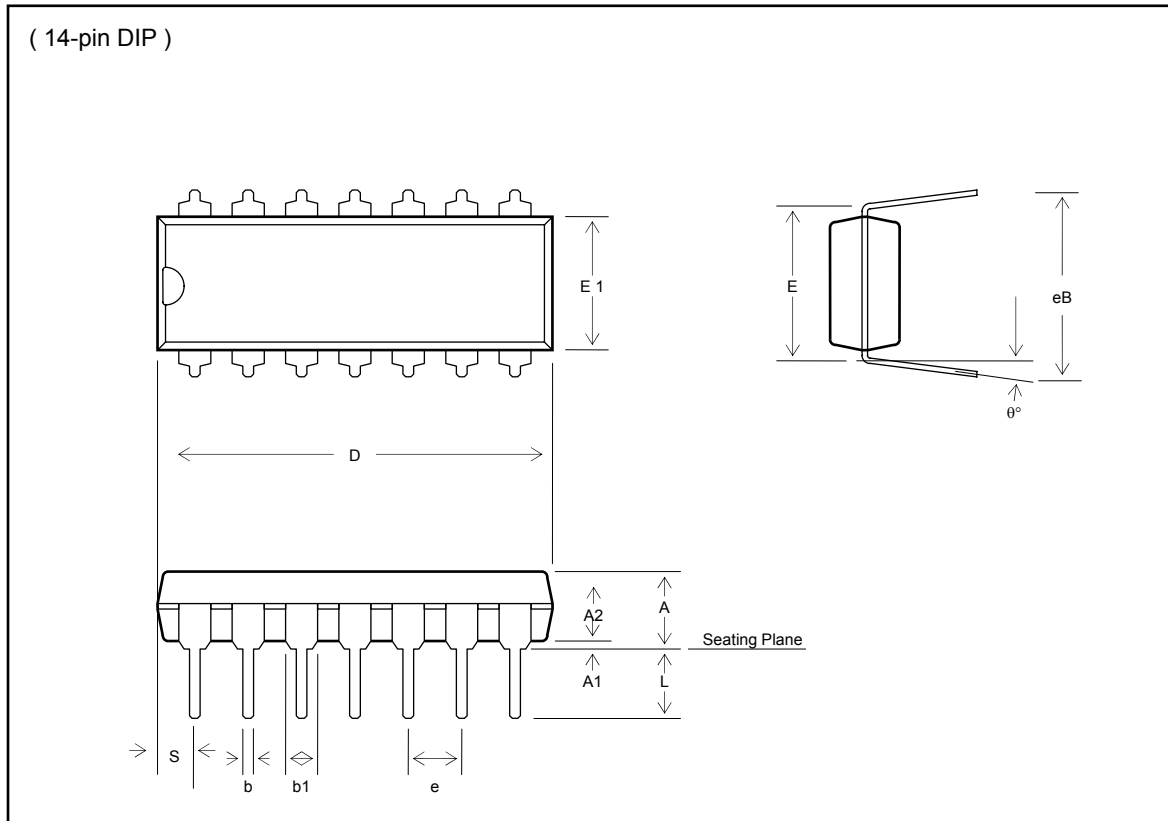

SYMBOL	DIMENSION (mm)		
	MIN.	NOM.	MAX.
A			5.334
A1	0.381		
A2	3.175	3.302	3.429
b	1.300	1.500	1.700
b1	0.400	0.480	0.560
D	18.669	19.495	20.320
E	7.366	7.620	7.874
E1	6.223	6.812	7.400
e	2.290	2.540	2.790
eB	8.509	9.017	9.525
L	2.540	3.175	3.810
S			2.390
θ°	0	7	15

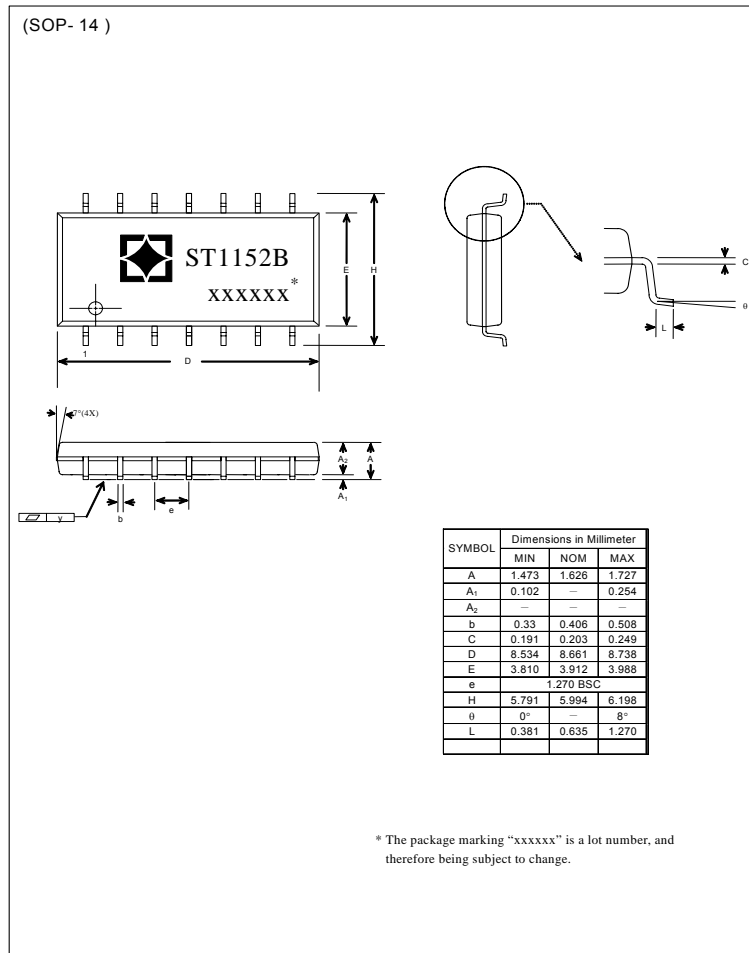

The products listed herein are designed for ordinary electronic applications, such as electrical appliances, audio-visual equipment, communications devices and so on. Hence, it is advisable that the devices should not be used in medical instruments, surgical implants, aerospace machinery, nuclear power control systems, disaster/crime-prevention equipment and the like. Misusing those products may directly or indirectly endanger human life, or cause injury and property loss.

Silicon Touch Technology, Inc. will not take any responsibilities regarding the misuse of the products mentioned above. Anyone who purchases any products described herein with the above-mentioned intention or with such misused applications should accept full responsibility and indemnify. Silicon Touch Technology, Inc. and its distributors and all their officers and employees shall defend jointly and severally against any and all claims and litigation and all damages, cost and expenses associated with such intention and manipulation.